



simply traceable

permanent mark with an electric pinmarker

DEEP
MARK

 MarkinBOX®



Compact Sized
Portable Marker
MB3315S

*Actual size

Available in 5 colors.



Red



Silver



Blue



Green



Black

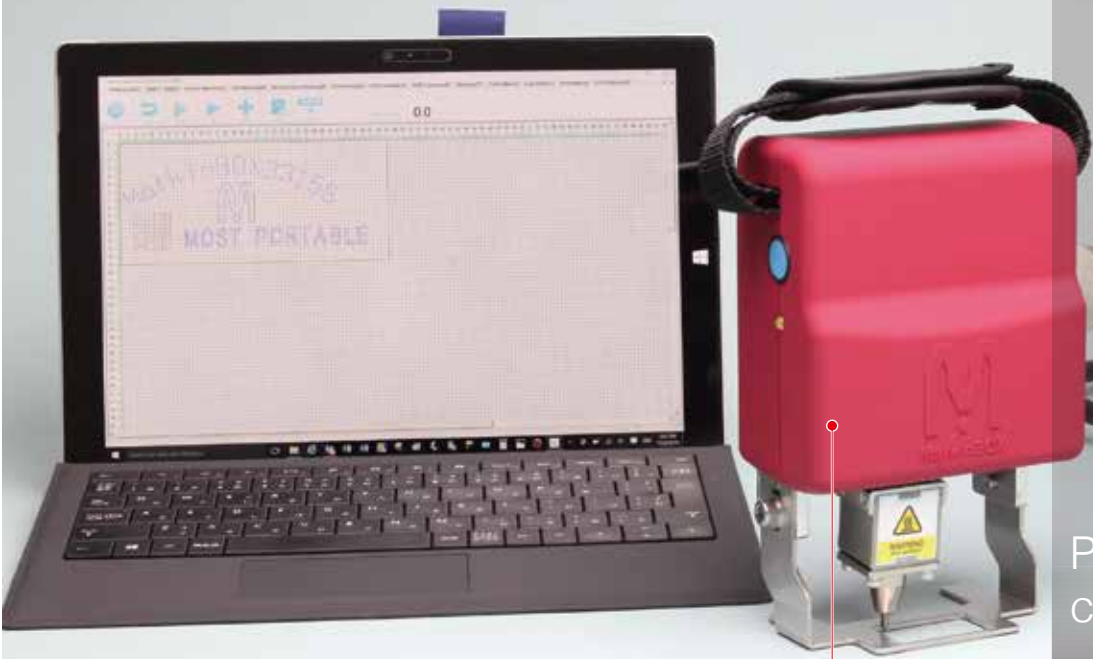

Made of impact-resistant polycarbonate finished with a rubber coating.

Portability-focused compact marker.

Marking area of X axis 33mm x Y axis 15mm.



Easy marking at any place due to the lightweight 1.5 kg (3.3lbs) only.

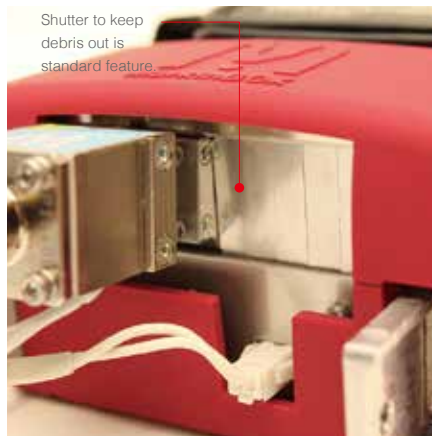

Shutter to keep debris out is standard feature.



A metal cover is provided as an option.

Workpiece Samples



Hardened steel (HRC62)



Metal casting



Middle Sized
Portable Marker
MB8020S

*Actual size

Available in 5 colors



Red



Silver



Blue



Green



Black



Made of impact-resistant polycarbonate finished with a rubber coating.

Mid-sized marker combining portability with a long horizontal marking area.

Marking area of X axis 80mm x Y axis 20mm.



Tool and post model (option).



Big Solenoid (BSD) for deeper marking is an option.



A metal cover is provided as an option.

Workpiece Samples



Plated mild steel



Round stainless steel

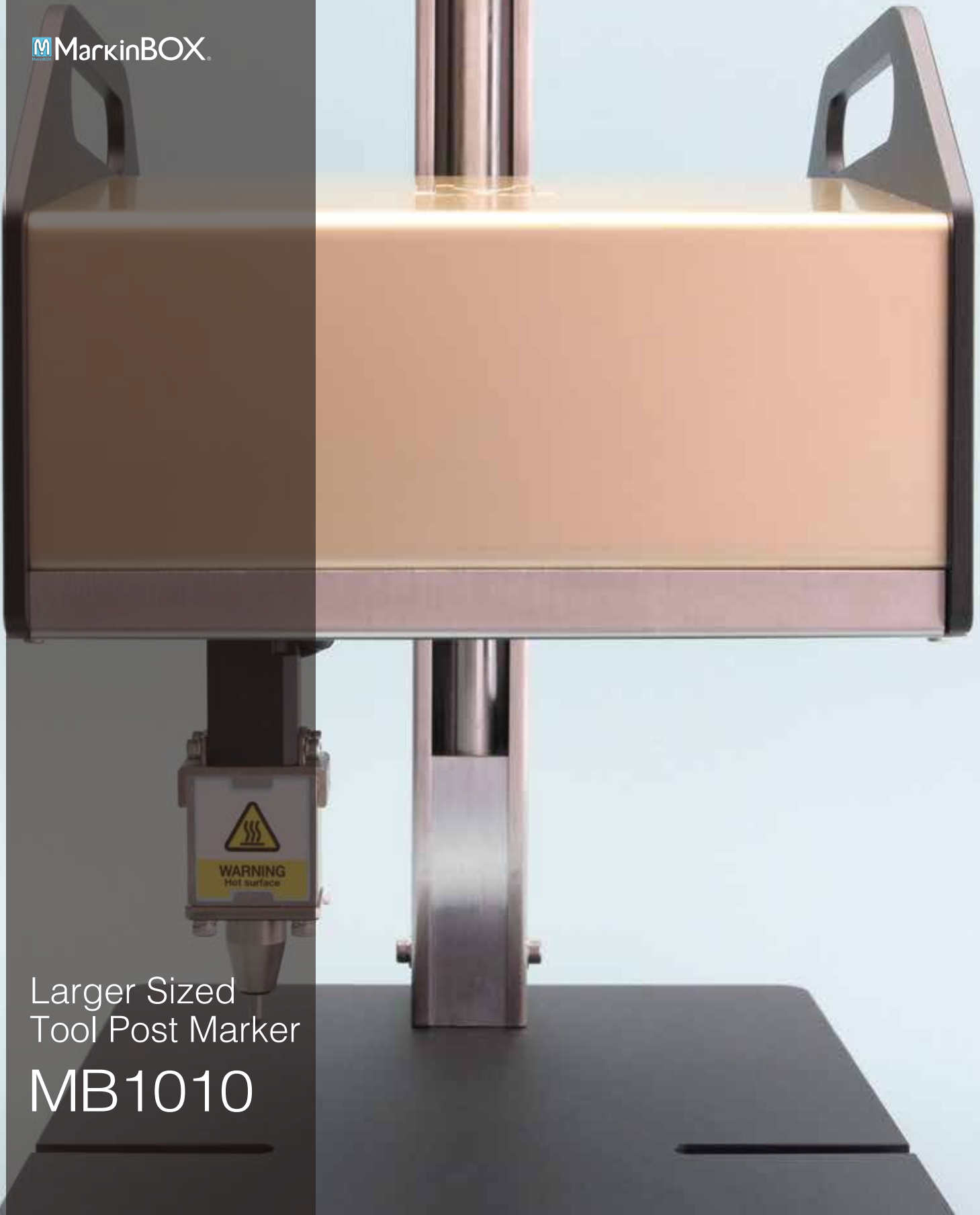

Larger Sized
Tool Post Marker
MB1010

Available in 5 colors



■ Champagne Gold



■ Wine Red



■ Silver



■ Gun Metal



■ Black

Larger marking area
more diverse needs.

Marking area of
X axis 100mm x Y axis 100mm.

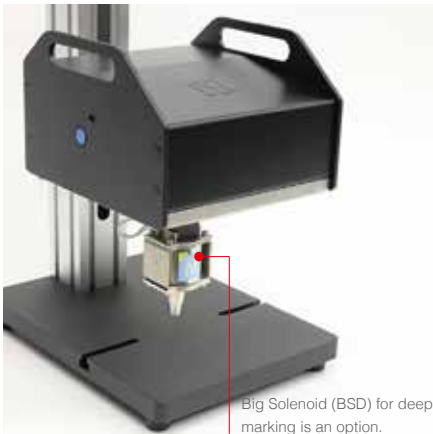

Big Solenoid (BSD) for deeper marking is an option.



Shutter to keep debris out is standard feature.



Portable model (option).

Workpiece Samples

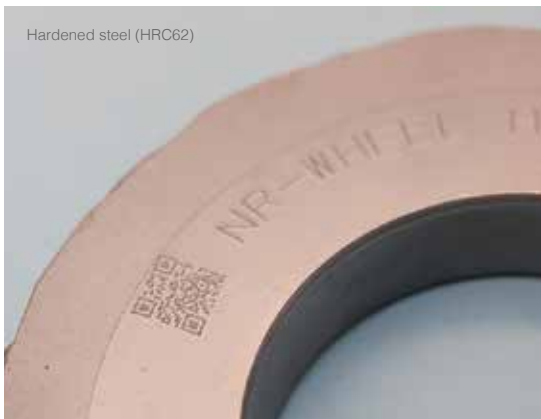

Hardened steel (HRC62)



Metal plates

Greater Sized
Tool Post Marker
MB2015

Available in 5 colors



Champagne Gold



Wine Red



Silver



Gun Metal



Black

The largest model in MarkinBOX series.

Marking area of
X axis 200mm x Y axis 150mm.



Workpiece Samples



sketchbook2

Software

Intuitive easy to use
WYSIWYG operation

One-touch icon-based
drawing.
Support for PC fonts.

Automatic conversion of
DXF data.
No tracing is required.

CSV data can be imported.
Excel and other csv data
can be easily marked.

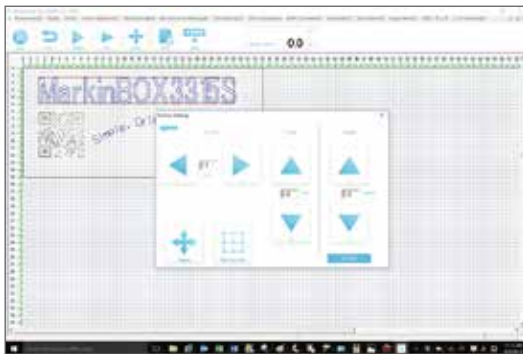

Sense of free drawing on paper and intuitive operation using icons; PC fonts also can be marked as they are.
*PC fonts are supported only when a PC is connected.

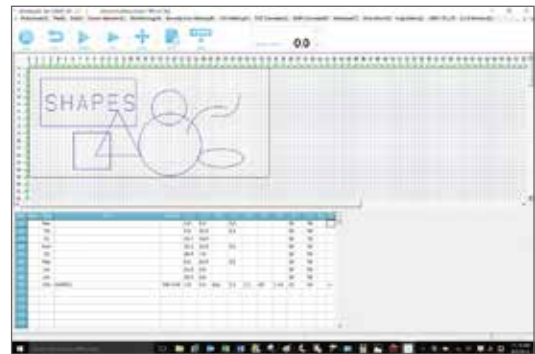

Rectangles, circles, straight lines, ellipses, triangles and other figures can be drawn using shape icons; thus simple markings can be easily created and marked.

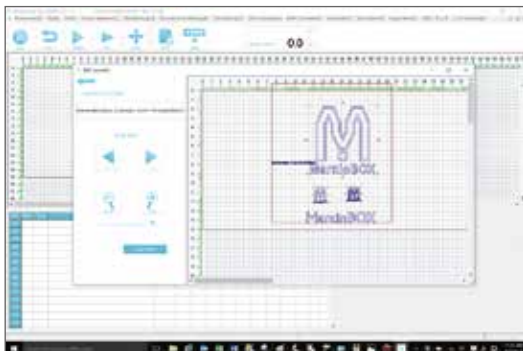

Automatic conversion of DXF data is standard included; input data can be automatically converted into MarkinBOX marking data.
* Straight lines, circles, ellipses and polygons are supported; splines and letters are not supported.

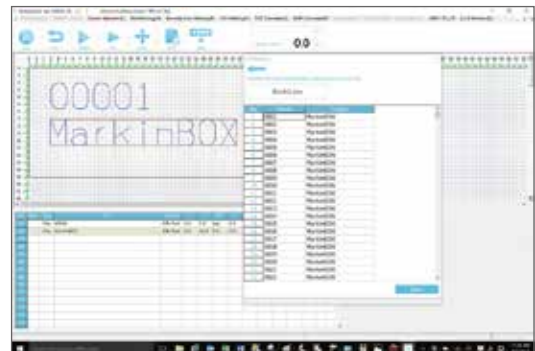

CSV marking is included as a standard; Excel (CSV format) and other databases can be retrieved with one click.

sketchbook 2 lite Mobile app

MarkinBOX with
easy to use
WIFI communication

*WiFi is an option.



*There is a uncomfortable WIFI communication case depend on the using environment.

Connectivity

① USB communication

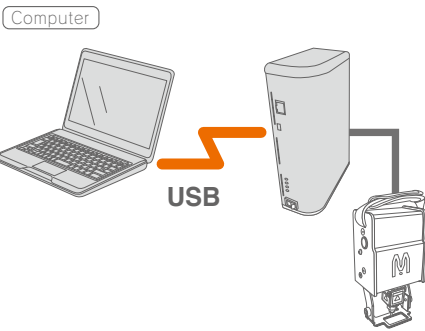

② Handheld device communication (*WiFi is an option.)

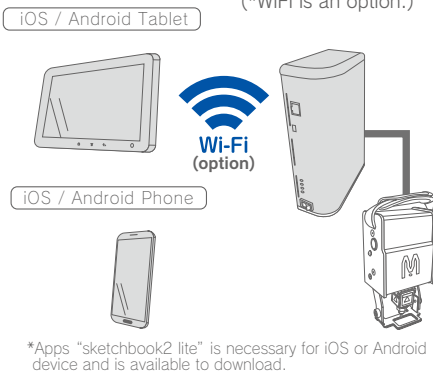

③ D.I/O communication

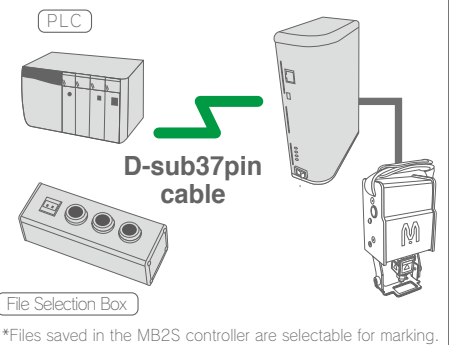

④ PLC communication

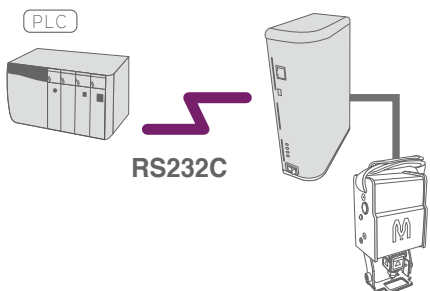

*The special program in PLC is necessary for this communication.

⑤ Network communication

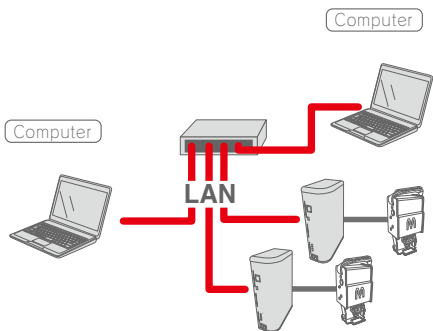

⑥ Fieldbus Communication

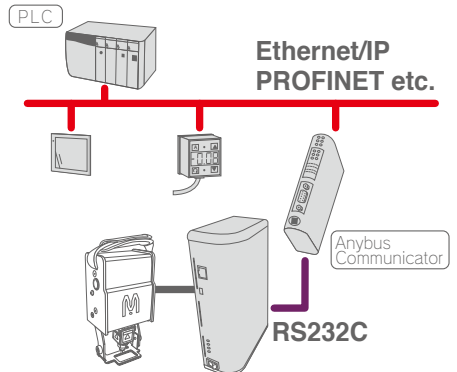

Rotary Device

Auto rotation MB Chuck Rotary

A supporter is provided as an option.

Available with all MarkinBOX series.

MB Chuck Rotary

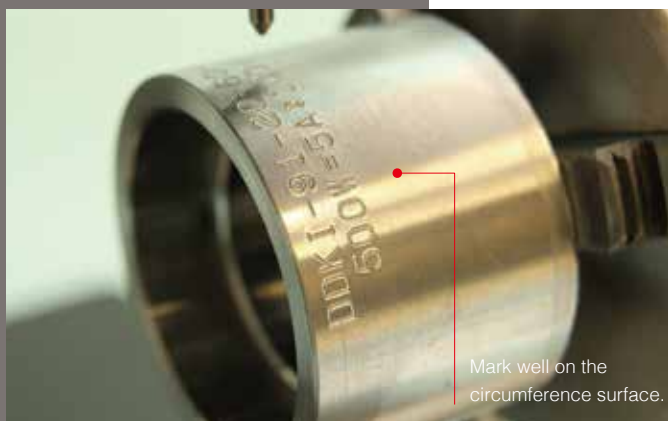

MB Chuck Rotary Specifications

Chuck specification	Chuck type	Grasping method	Work size	Grasp weight
Standard (φ80)	External jaws	Inside diameter grasp (pipe)	φ25~φ70mm (1" ~ 2.7")	Approx. 6kg (13.2lbs)
		Outside diameter grasp	φ10 ~ φ25mm (0.4" ~ 0.9")	
Large (option) (φ100)	External jaws	Outside diameter grasp	φ22 ~ φ63mm (0.9" ~ 2.4")	
		Inside diameter grasp (pipe)	φ30 ~ φ90mm (1.2" ~ 3.5")	
	Internal jaws	Outside diameter grasp	φ10 ~ φ30mm (0.4" ~ 1.1")	
External dimensions / Weight		100(W)×196(D)×218(H) / 4.1kg (9lbs)		

MB Chuck Rotary Overview

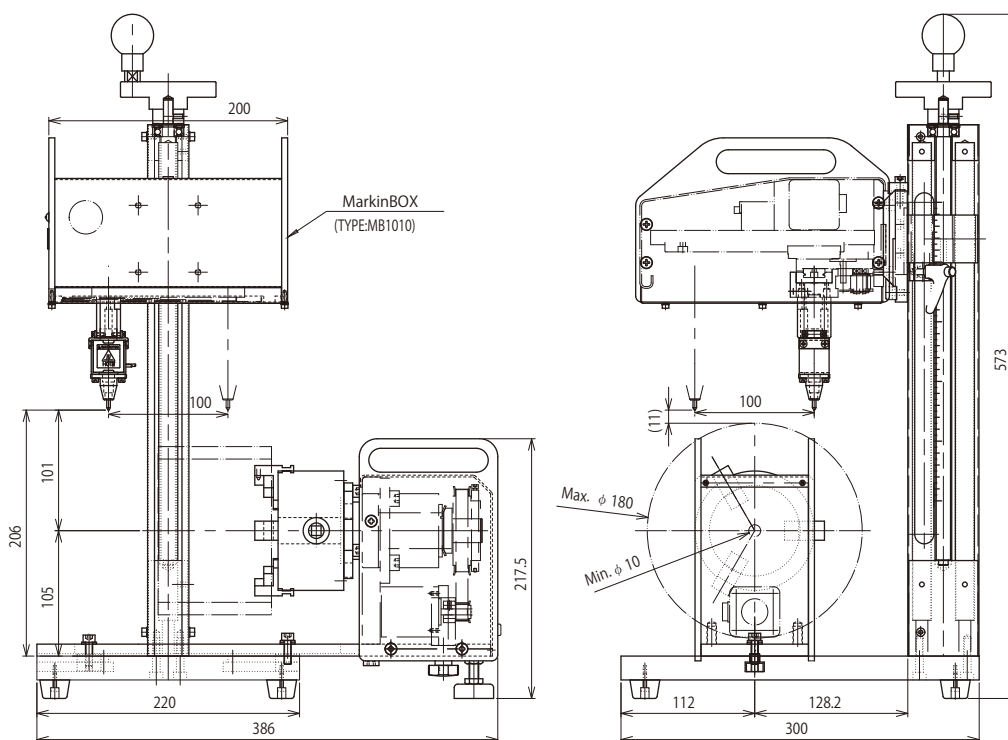

Rotary Device

Manual rotation S-Rotary



MB S-Rotary

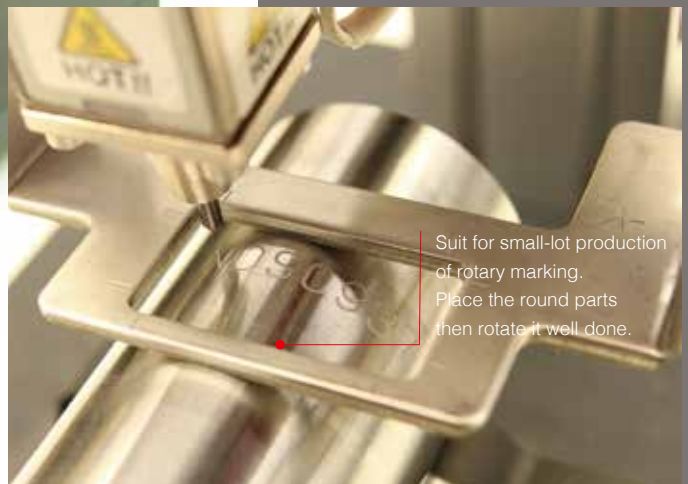

Suit for small-lot production of rotary marking.
Place the round parts then rotate it well done.

MB S-Rotary Specifications

Head model	Workpiece diameter	Continuance digits	Pause time
3315S/8020S	$\phi 10 \sim \phi 160\text{mm}$ (0.4" ~ 6.2")	1 ~ 5 words	0.5 ~ 5 (sec)

MB S-Rotary Overview

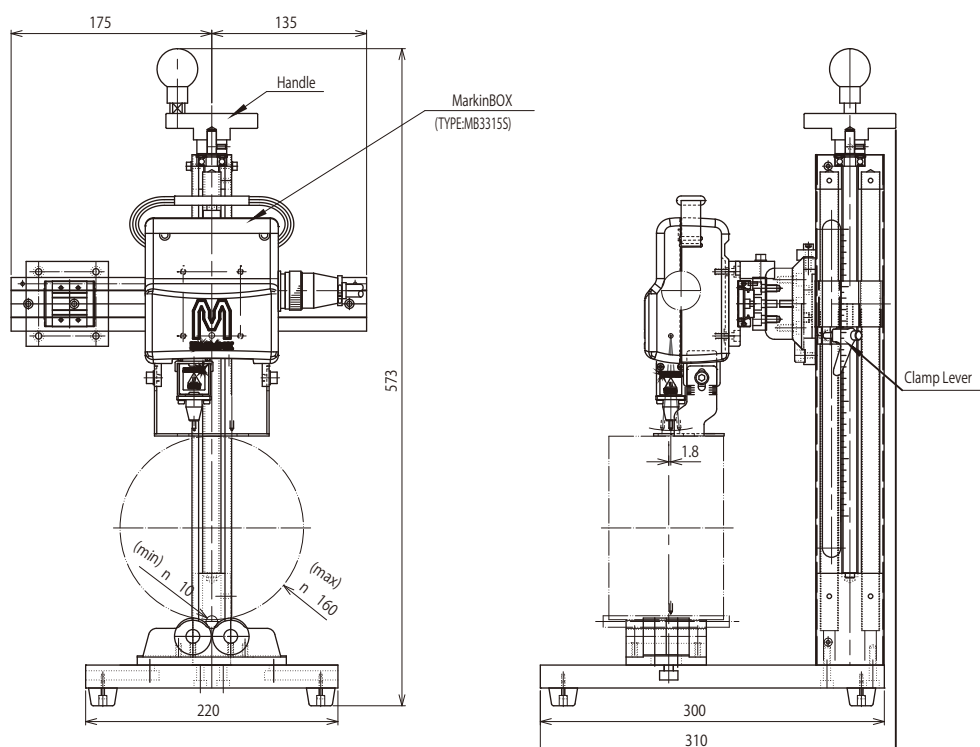

Accessories



File Selection Box.
Files saved in the MB2S controller are selectable for marking.



Foot Switch



MB2S Controller L Bracket.
Installable in the cabinet by DIN Rail Holder.



Hands-free Pocket



Hands-free Magnet



Magnet Guide

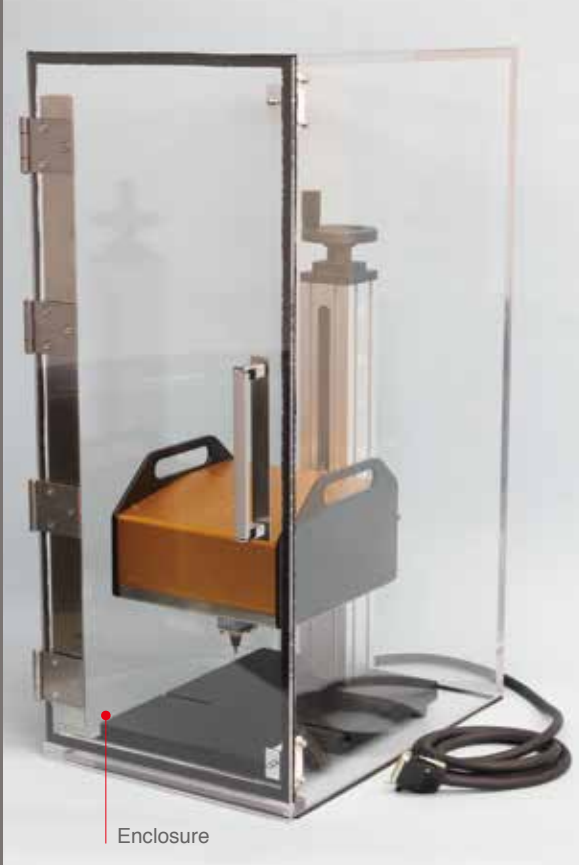

Enclosure



Water and Dustproof

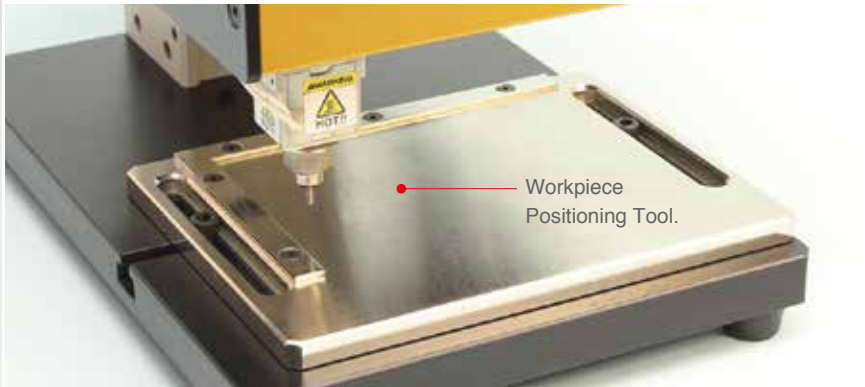

Workpiece Positioning Tool.

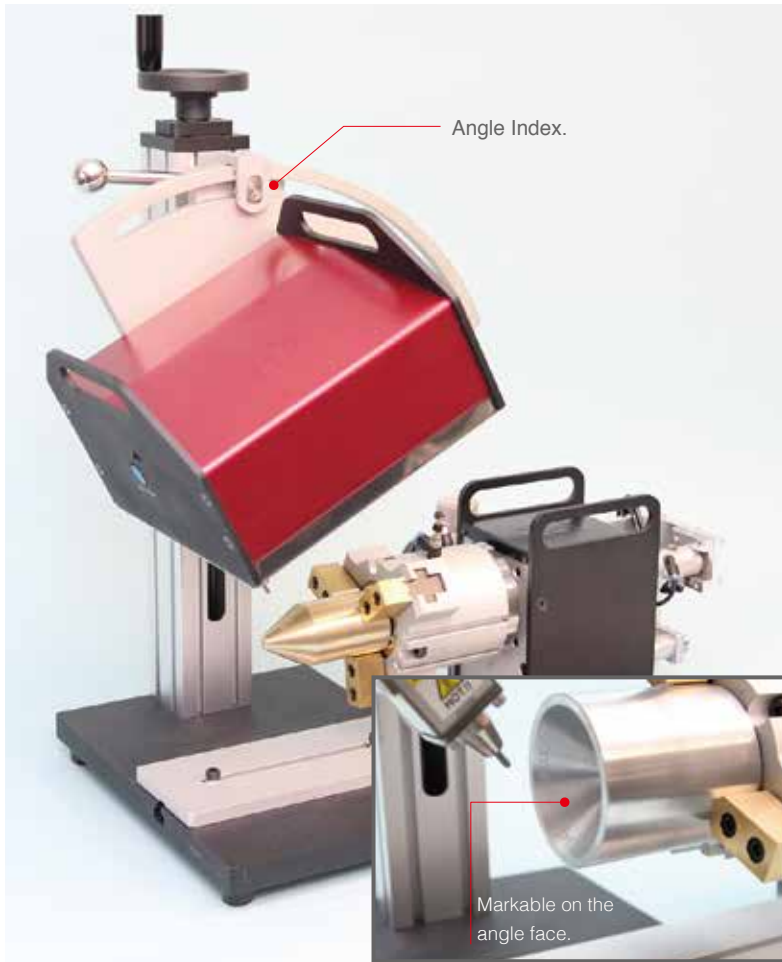

Stylus Pin Specification

Dimensions

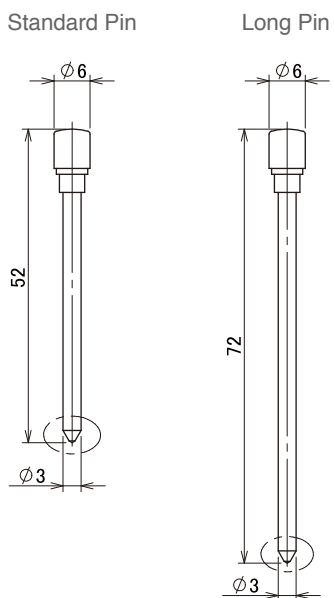

Tip Angle

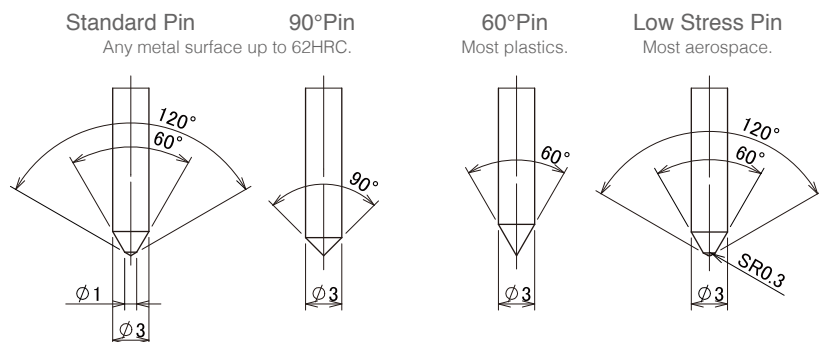

Stylus Pin Specifications table

	Standard Pin	High Grade Pin
Hardness	HRA92	HRA93.6
Length	52mm (*72mm)	
Tip Angle	4 types (Refer to the drawing)	
Regrind	Available	

MB 3315S Overview

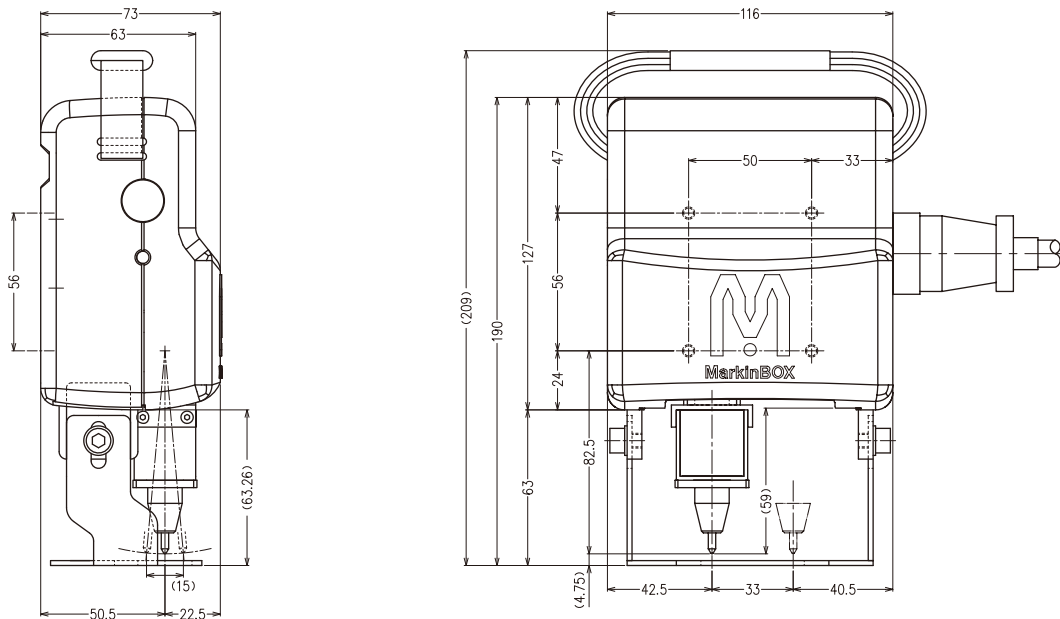

MB 8020S Overview

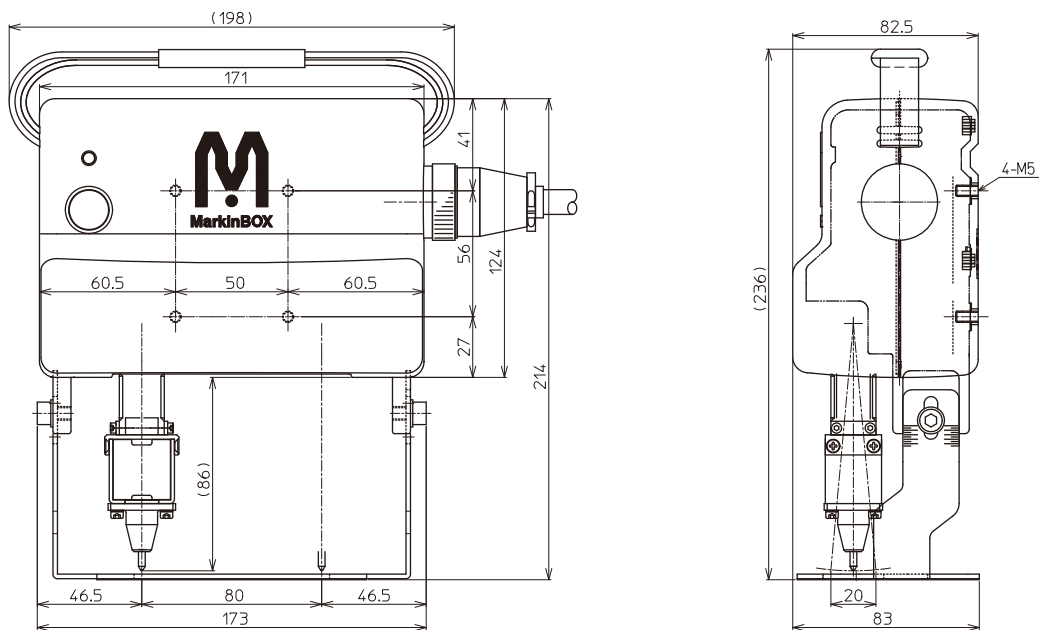

MB2S Controller Overview

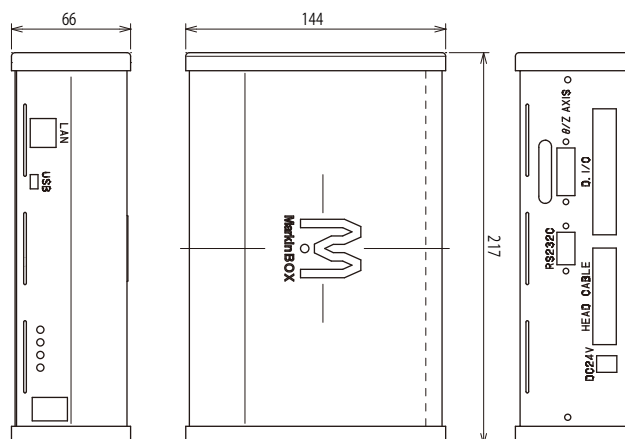

MB 1010 Overview

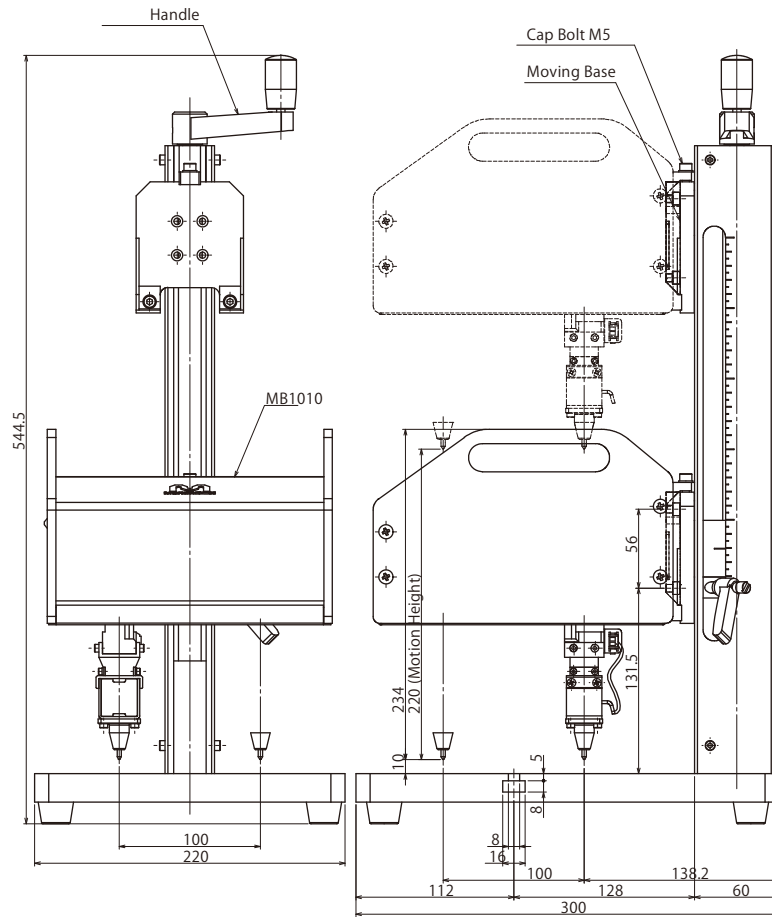

MB 2015 Overview

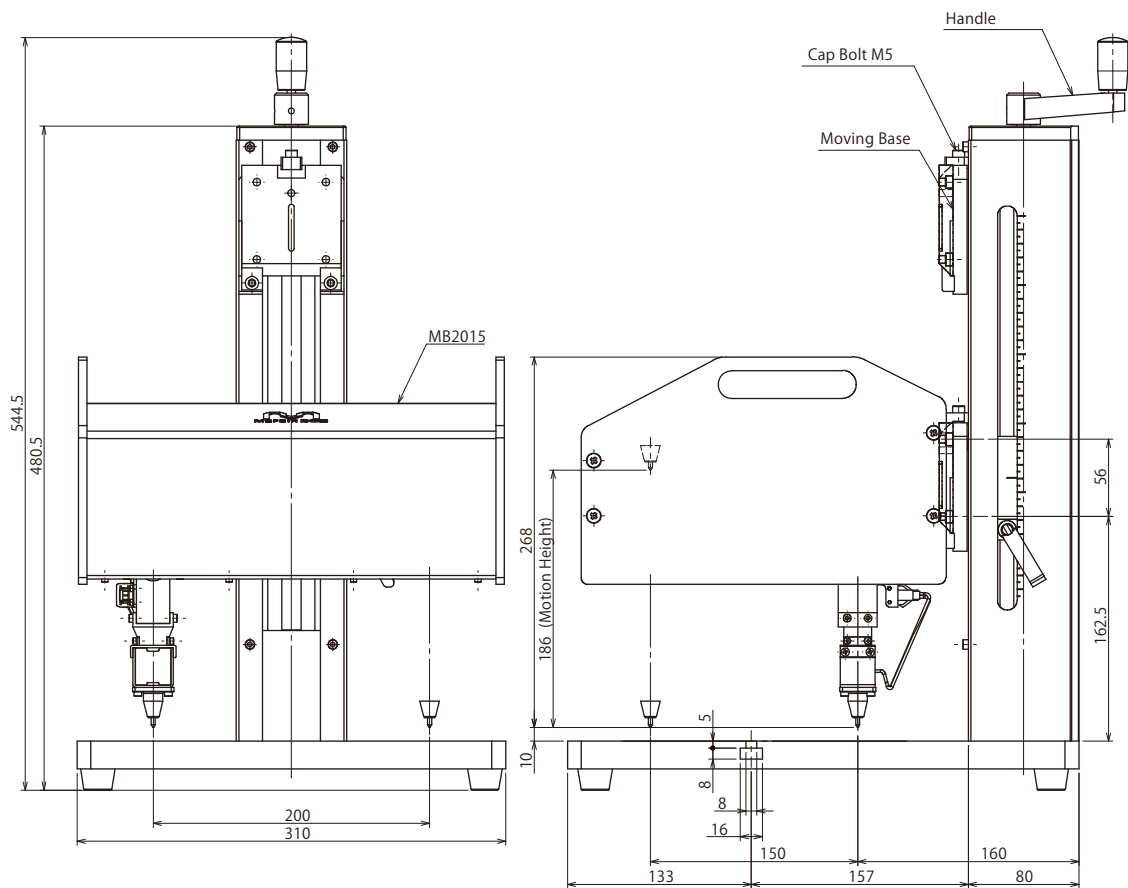

Specifications

MarkinBOX Specification table

	MB3315S	MB8020S	MB1010	MB2015
Marking area	X axis 33mm (1.3") x Y axis 15mm (0.6")	X axis 80mm (3.1") x Y axis 20mm (0.8")	X axis 100mm (4") x Y axis 100mm (4")	X axis 200mm (8") x Y axis 150mm (6")
Standard cable length	3M (10')	3M (10')	2M (6')	2M (6')
Head dimensions	116mm (4.6") x 73mm (2.9") x 190mm (7.5")	173mm (6.8") x 83mm (3.3") x 214mm (8.4")	200mm (7.9") x 217.5mm (8.6") x 228mm (9")	308mm (12") x 269mm (10.6") x 249mm (9.8")
Head weight	1.5kg (3.3lbs)	2.1kg (4.6lbs)	4.5kg (9.9lbs)	6.3kg (13.9lbs)
Tool and post dimensions	220mm (8.7") x 300mm (11.8") x 573mm (22.6")			310mm (12.2") x 370mm (14.6") x 544mm (21.4")
Tool and post weight	7kg (15.4lbs)			10.7kg (23.6lbs)

	MB2S Controller
Power	AC100V ~ 240V 50/60Hz
Dimensions	66mm (2.6") x 144mm (5.7") x 217mm (8.5")
Weight	1.4kg (3.1lbs)
Connectivity	USB / RS232C / LAN / WIFI (Option)
D.I/O	input 12 pins / output 8 pins Save up to 255 files

sketchbook2 Specification table

OS	Windows 7 or higher
Operating environment	Memory 1 GB or more, monitor resolution 1280 x 768 or higher
Corresponding model	MB3315S, MB8020S, MB1010, MB2015
Settable character height	0.1 mm or larger (0.1 mm pitch) to maximum Y value
Settable character width	Character height x 1% ~ 200%
Horizontal character pitch	0.1mm~
Fonts	[Original MarkinBOX fonts] MB font, Elegant font, 5x7 font * Including alphanumeric characters, hiragana, katakana, miscellaneous symbols [PC fonts] * PC fonts are valid only when a PC is always on
Logos	JPEG, BMP data are read and registered on the creation screen Automatic conversion of DXF data * Straight lines, circles, ellipses, polygons supported
Serial marking	0000001 ~ 9999999
Calendar marking	Year, month, day, hours, minutes, seconds, Julian dates
2D codes	Data matrix, QR code
Number of creation fields	Up to 50 fields
Barcode reader	Automatic marking of data from barcode reader
File communication	Up to 255 files can be sent to the controller
Password functions	Two-level password setting (administrator/User)
Others	Drawing editing functions supported

Note: Specifications can be changed without prior notice for quality improvement.

MB1010 Example connection

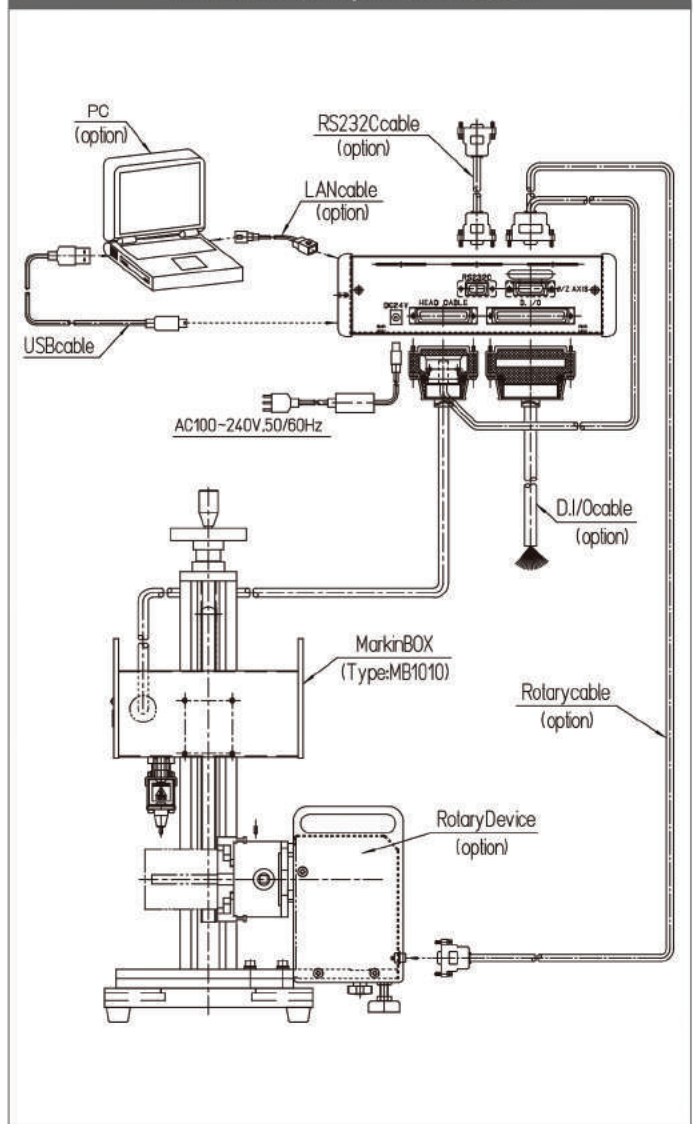

MB Metal Technologies, LLC
403 S Hawley Rd
Milwaukee, WI 53214
P# 855-897-1439
www.markinbox.com
www.mbmataltech.com